

# PSA2100W

## PRESSURE SWITCH

RANGE

2 ~ 12 ...  
**100 psi**

SWITCH

One  
**SPDT**

MEDIA

**Liquid  
&  
Gas**



Approvals:



IP66

### SPECIFICATION

<b>MODEL</b>	PSA2100W
<b>PROCESS CONNECTION</b>	1/4", 1/2" PT, NPT, PF Female M20 x P1.5 Female
<b>MATERIALS</b>	Housing : Die cast aluminum alloy with paint Wetted parts : 316SS
<b>PRESSURE ELEMENT</b>	Welded type diaphragm
<b>SWITCH FORM</b>	One SPDT
<b>SWITCH DATA</b>	20Amp @ 125, 250 or 480VAC; 5Amp, DC125V
<b>CONDUIT CONNECTION</b>	1/2"NPT Female, standard 3/4"NPT Female M20 x P1.5 Female
<b>TEMPERATURE LIMIT</b>	-30 ~ 205°C

CODE	ADJUSTABLE RANGE	DEAD BAND "E" POSITION	MAX. PRESSURE PROOF
04R	2 ~ 12 psig	1.2 ~ 3	1000 psig
10R	2 ~ 16 psig	1.6 ~ 4	1000 psig
20R	2 ~ 20 psig	2 ~ 5	1000 psig
30R	3 ~ 28 psig	2.8 ~ 7	1000 psig
40R	7 ~ 100 psig	9.9 ~ 28.4	1000 psig

### DIMENSION (mm)

※ 제품의 사양에 따라 변경 될 수 있습니다

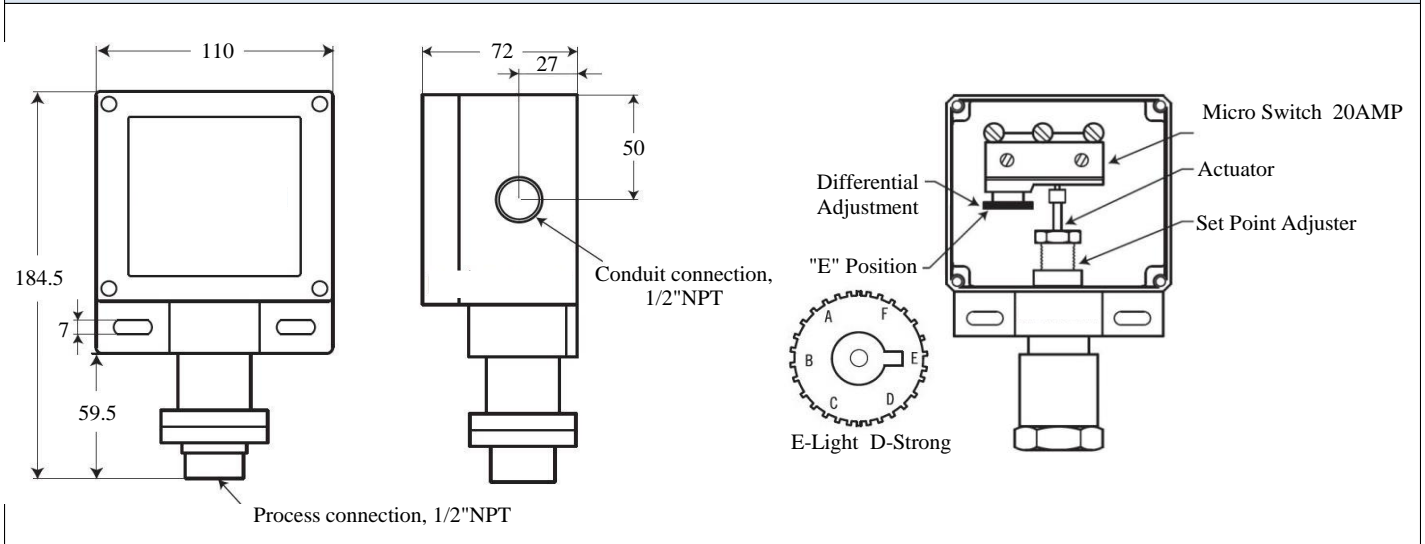

### Range Setting Method

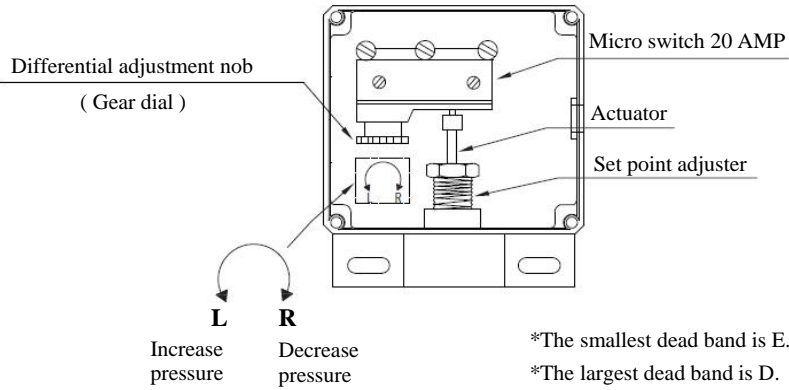

### Principle

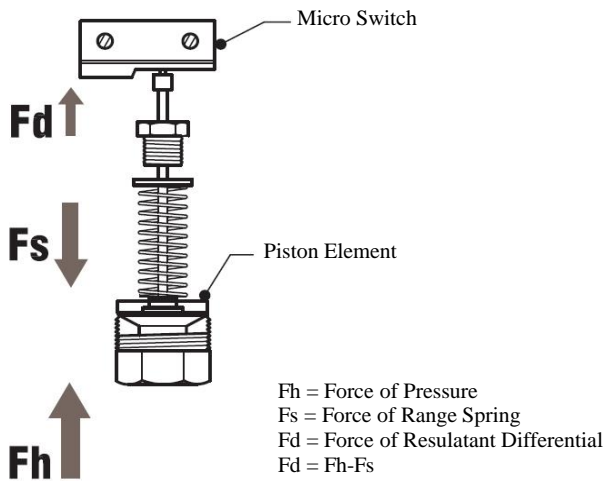

### Process Installed Instruction

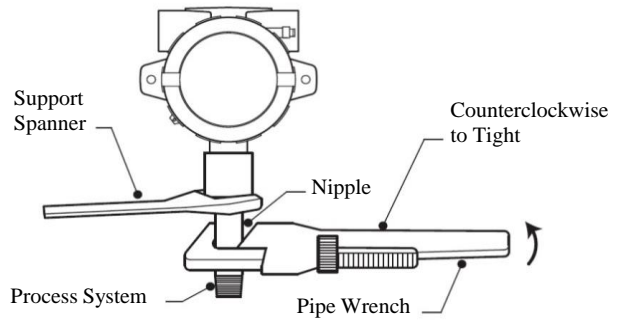

### Process Installed Instruction

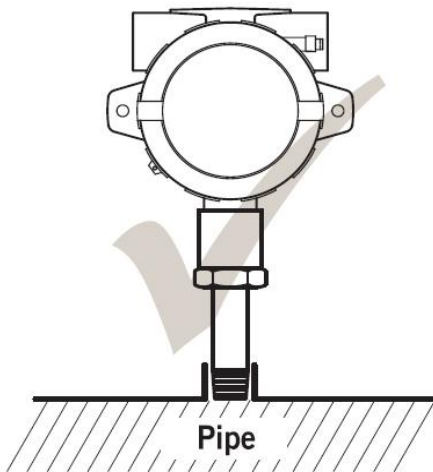

Correct : "Vertical" installation

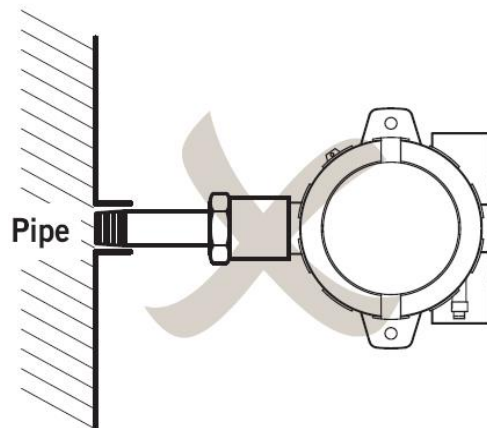

Error : "Horizontal" installation

| FLOW | | PRESSURE | | TEMPERATURE | | AC | | DC | | BATTERY | | OUTPUT | | CONTACT | | DISPLAY |

## Ordering Information

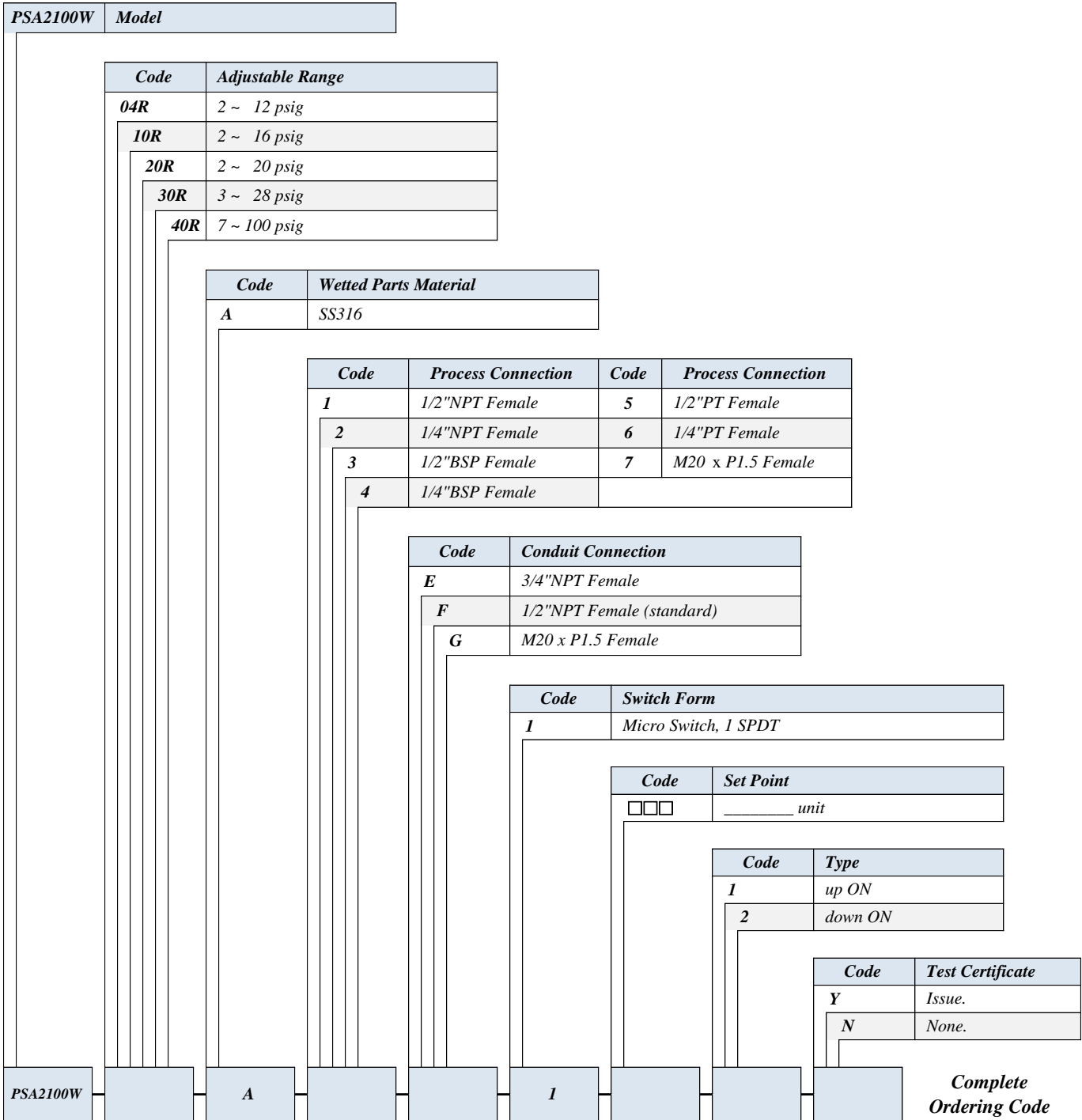

| FLOW | | PRESSURE | | TEMPERATURE | | AC | | DC | | BATTERY | | OUTPUT | | CONTACT | | DISPLAY |